

2+2 3+3

Morrison, Currents and Reff Raceways

Morrison, Currents and Reff Raceways. More. Better.

Knoll pioneered 2+2, the office systems raceway with the right balance of convenience power and protected power for computer-intensive offices. 2+2 delivers twice as much “clean” computer power as single-isolated circuit systems.

Now Knoll offers two powerful alternatives to 2+2: high-performance 3+3 and optional 4 · 4 · 2 raceways for Morrison, Currents and Reff.

3+3 delivers six circuits from a single power supply: three convenience circuits and three separate, protected circuits — enough power for 60 or more duplex outlets. This can significantly reduce the cost of installation by reducing the number of power infeeds.

Like 2+2, 3+3 features separate grounds and heavy-duty, 10-gauge neutrals to protect sensitive electronic equipment. 4 · 4 · 2 is a four-circuit, 10-wire system for special applications requiring an independent neutral for each circuit.

2+2, 3+3 and 4 · 4 · 2 components have been designed specifically for Morrison panels, Morrison Network desks, Reff panels and Beltway, and Currents service walls and desks.

Simple Components

Power rails

Power rails for Morrison and Reff correspond to panel and desk widths. The power rail accepts one or two duplex outlets on each face. Multiple outlet power rails for 48" and wider panels accept four outlets on each side. Power rails are also available for the Currents service wall base.

Each end of the power rail has branching capability for connectors or jumpers to adjacent power rails.

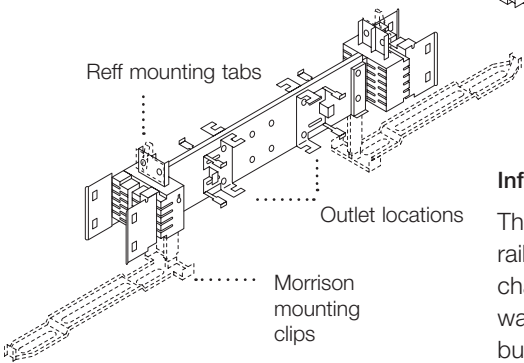

Outlets

Duplex outlets are preconfigured to access any one of the six circuits. Outlets on protected circuits can be ordered with an orange face and a black triangle or a black face and an orange triangle to indicate special circuits. Surge suppressor outlets are available to protect an entire circuit. Duplex outlets are interchangeable among Morrison, Reff and Currents.

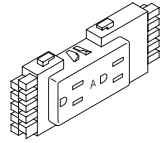

Morrison Access ceiling infeed passes through one side of a vertical raceway and connects to the end of a power rail in the adjacent panel base.

Currents power infeed snaps into base of the outlet module (or end of the base raceway power rail) without displacing an outlet position.

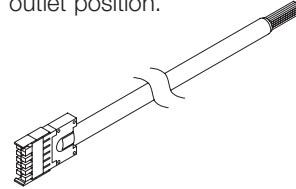

Infeeds

The modular infeed engages into the power rail at any outlet position. The elbow may be changed from right to left and includes watertight conduit to connect to the building power supply.

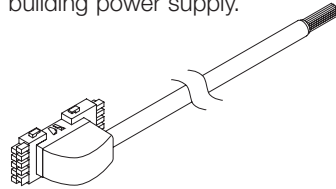

Power connectors and jumpers

Power connectors and jumpers snap into either port at the end of a power rail. Connectors join power in adjacent panels or desks; jumpers pass through intermediate panels that have no outlets. Connectors are also available to link Morrison panels with powered Network desks, to connect Reff beltway with the panel base and Currents service wall with attached panels or desks.

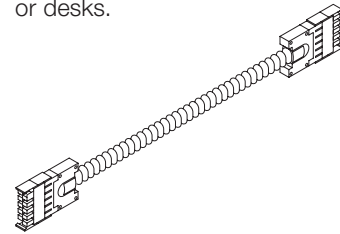

Outlet modules for Currents

Outlet modules for Currents service walls accept one or two outlets on each face, above or below worksurface height. Distribution blocks provide branching capability for up to four jumpers (or one infeed and three jumpers).

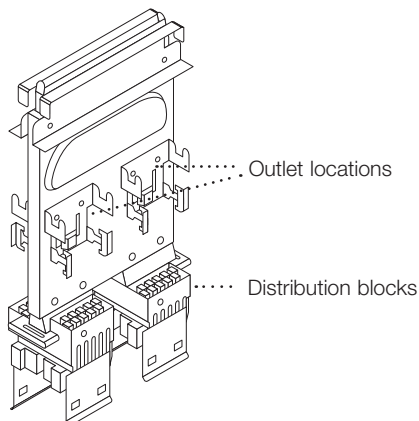



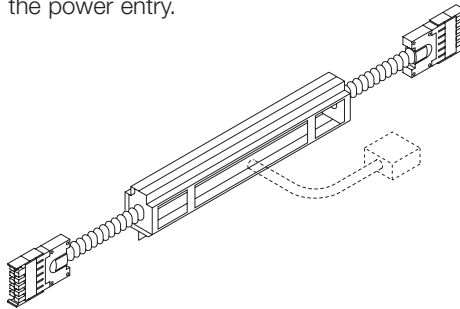



The hardwire infeed kit includes a New York City code-approved box that mounts within the panel base to make a hardwire connection to power rails on either side of the power entry.

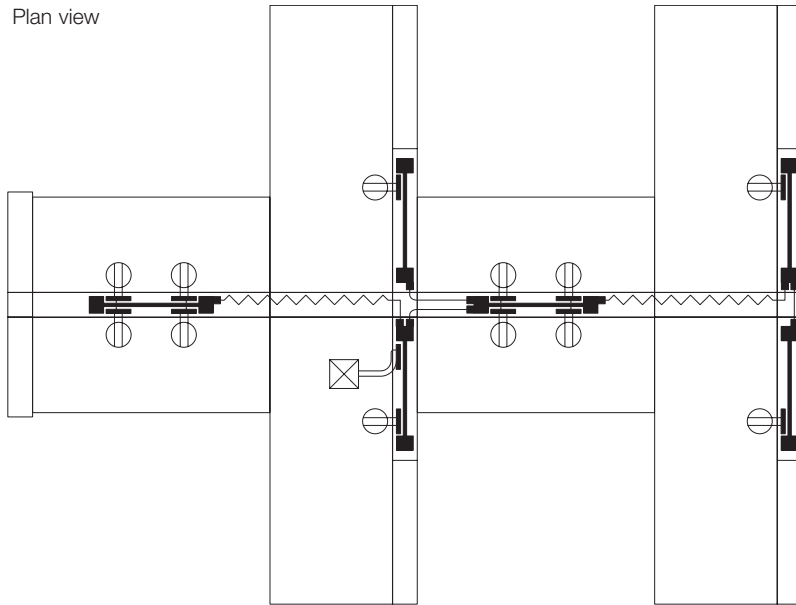

Typical Workstation Cluster: Morrison or Reff Panels

Plan view



-  Power rail
-  Duplex outlet
-  Power infeed
-  Power connector
-  Jumper

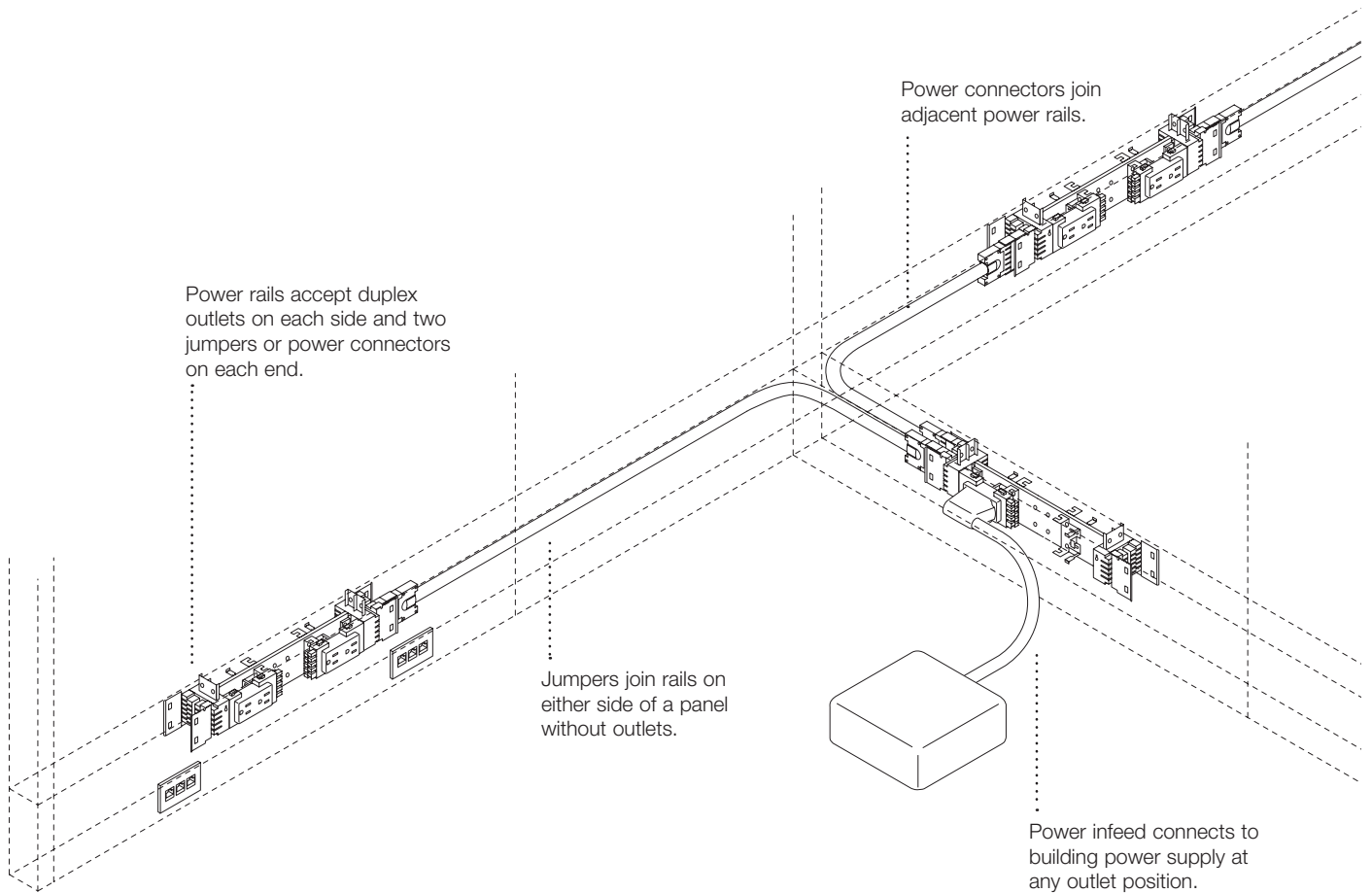

Currents

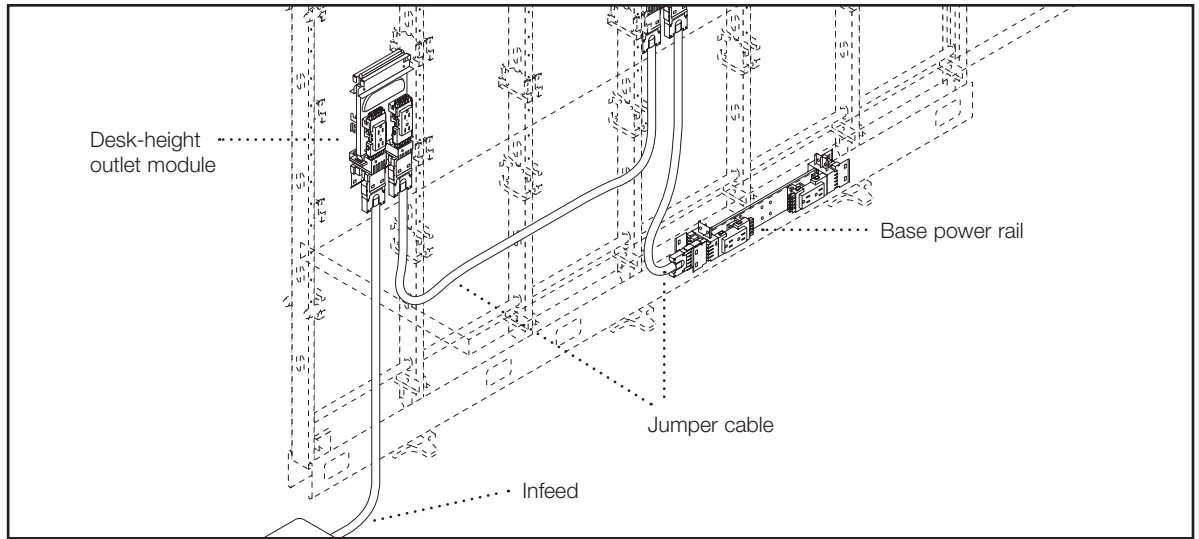

Morrison Access

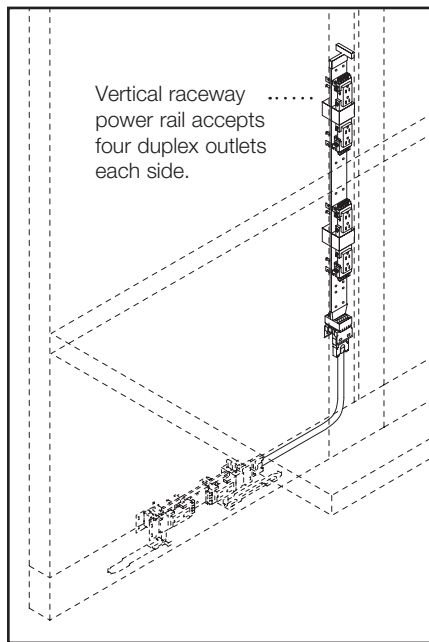

Morrison Network

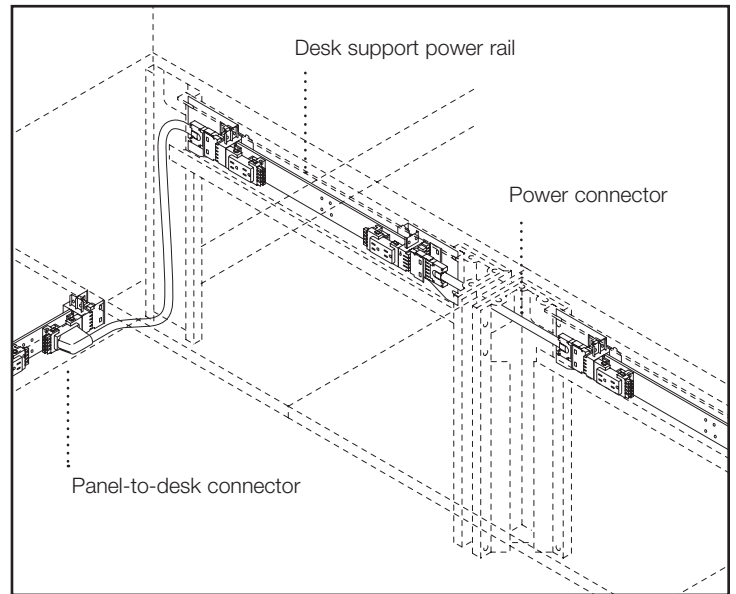

Reff Beltway

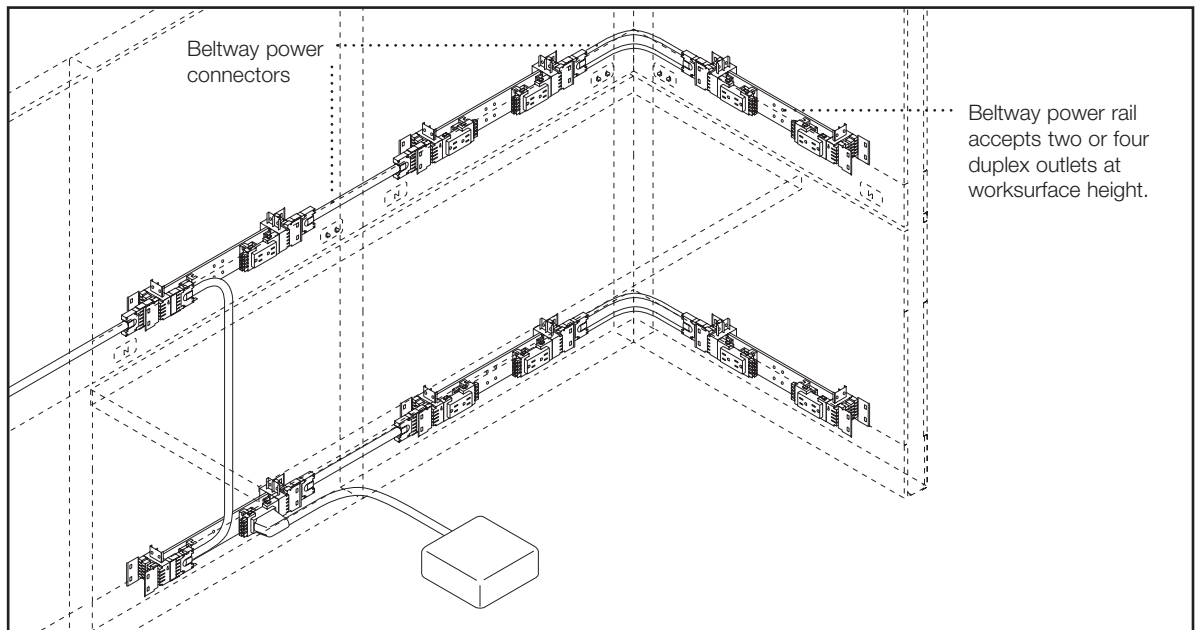

Technical Specifications

2+2

Four 20-amp circuits, nondirectional 8-wire configuration: four hots, two neutrals (10 gauge, 35A rated), two grounds.

Power rails and outlet modules: steel with molded polypropylene distribution blocks.

Connectors/jumpers: flexible steel conduit with strain relief.

Outlets: molded polycarbonate, preconfigured duplex on any one of four circuits, indicated as A, B (black), X, Y (black, orange, or black with orange triangle).

Infeed: molded plastic shroud, watertight conduit with 6' whip, snap-in fit at any outlet position in rail or into outlet module distribution block; or hardwire box in center of panel base raceway.

Typical circuiting, cluster of eight workstations: 8 convenience duplexes on each circuit A, B; four computer duplexes on each circuit X, Y.

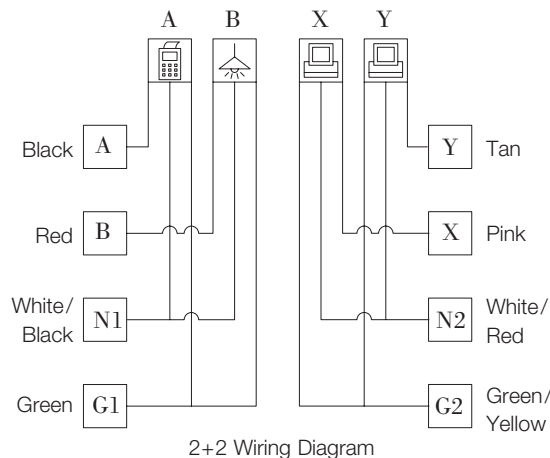

2+2 Wiring Diagram

3+3

Six 20-amp circuits, nondirectional 10-wire configuration: six hots, two neutrals (10 gauge, 35A rated), two grounds.

Power rails and outlet modules: steel with molded polypropylene distribution blocks.

Connectors/jumpers: flexible steel conduit with strain relief.

Outlets: molded polycarbonate, preconfigured duplex on any one of six circuits, indicated as A, B, C (black), X, Y, Z (black, orange, or black with orange triangle).

Infeed: molded plastic shroud, watertight conduit with 6' whip, snap-in fit at any outlet position in rail or into outlet module distribution block; or hardwire box in center of panel base raceway.

Typical circuiting, cluster of 12 workstations: eight convenience duplexes on each circuit A, B, C; four computer duplexes on each circuit X, Y, Z.

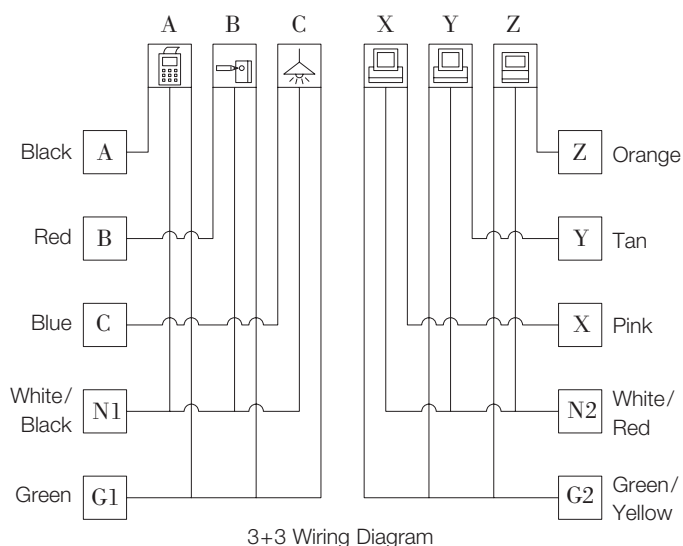

3+3 Wiring Diagram

4-4-2

Four 20-amp circuits, nondirectional 10 wire configuration: four hots, four neutrals (12 gauge), two grounds.

Power rails and outlet modules: steel with molded polypropylene distribution blocks.

Connectors/jumpers: flexible steel conduit with strain relief.

Outlets: molded polycarbonate, preconfigured duplex on any one of four circuits, indicated as 1, 2, 3, 4 (black or black with orange triangle).

Infeed: molded plastic shroud, watertight conduit with 6' whip, snap-in fit at any outlet position in rail or into outlet module distribution block (Currents); or hardwire box in center of panel base raceway.

Typical circuiting, cluster of eight workstations: 8 convenience duplexes on each circuit 1, 2; four computer duplexes on each circuit 3, 4.

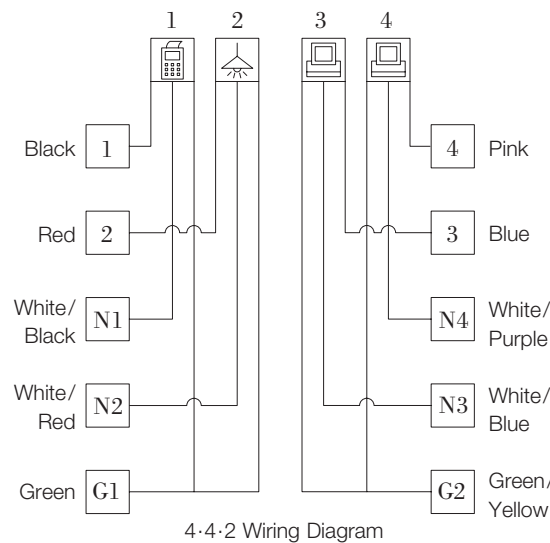

4-4-2 Wiring Diagram

Note: Outlets on circuits with dedicated ground must be specified orange face with black triangle or black face with orange triangle.

Approvals: Morrison, Currents and Reff systems raceways are UL listed, CSA approved and comply with UL 1286 and CSA 203.1 electrical and mechanical safety standards.

Morrison / Currents UL file no. E76704 CSA File no. LR62867

Reff UL file no. E76558 CSA File no. LR62867

2+2, 3+3 and 4-4-2 components are also listed under UL file no. E30326 and CSA no. LR55923.